

- NOTE
- ① This product is packaged in tray. (24pcs/tray)
 - ② Blemish and hit mark can be occurred through out the manufacturing process which doesn't affect quality level. Also, black spot could be observed on the surface of housing.
 - ③ For the contact NO., adjacent two pairs of leads placed back-to-back (4 leads in total) compose one line.
 - ④ Misalignment absorbing range: ±0.3mm max.
 - ⑤ The dimension in parentheses are for references.
 - ⑥ Lot NO. is indicated at either one of the position as shown.
 - ⑦ Pay attention to the recommended PCB thickness and finished through-hole dimensions. Low retention force to PCB could induce angled mounting due to the unbalanced center of the connector.

NO.	MATERIAL	FINISH	REMARKS	NO.	MATERIAL	FINISH	REMARKS
2	Copper alloy	Contact area:Gold-plating 0.1μm Lead area:Tin-plating 1.0μm Under plating:Nickel 1.0μm		4	Phosphor bronze	Tin-plating 3.0μm Under plating:Nickel 1.0μm	
1	Polyamide	Black UL94V-0		3	Copper alloy	Contact area:Gold-plating 0.1μm Lead area:Tin-plating 1.0μm Under plating:Nickel 1.0μm	
5				5	Polystyrene		

UNITS	SCALE	COUNT	DESCRIPTION OF REVISIONS	DESIGNED	CHECKED	DATE
mm	2 : 1	△	APPROVED : HS. OKAWA 14.09.12 CHECED : KN. SHIBUYA 14.09.12 DESIGNED : DK. AIMOTO 14.09.12 DRAWN : DK. AIMOTO 14.09.12			

DRAWING NO.	PART NO.	CODE NO.
EDC3-359163-00	FX30B-2P-7.62DS	CL570-3404-8-00

Recommended hole pattern dimension of PCB(5:1)
 (Connector mounting side, PCB thickness:t=1.6mm) $\triangleleft 7$

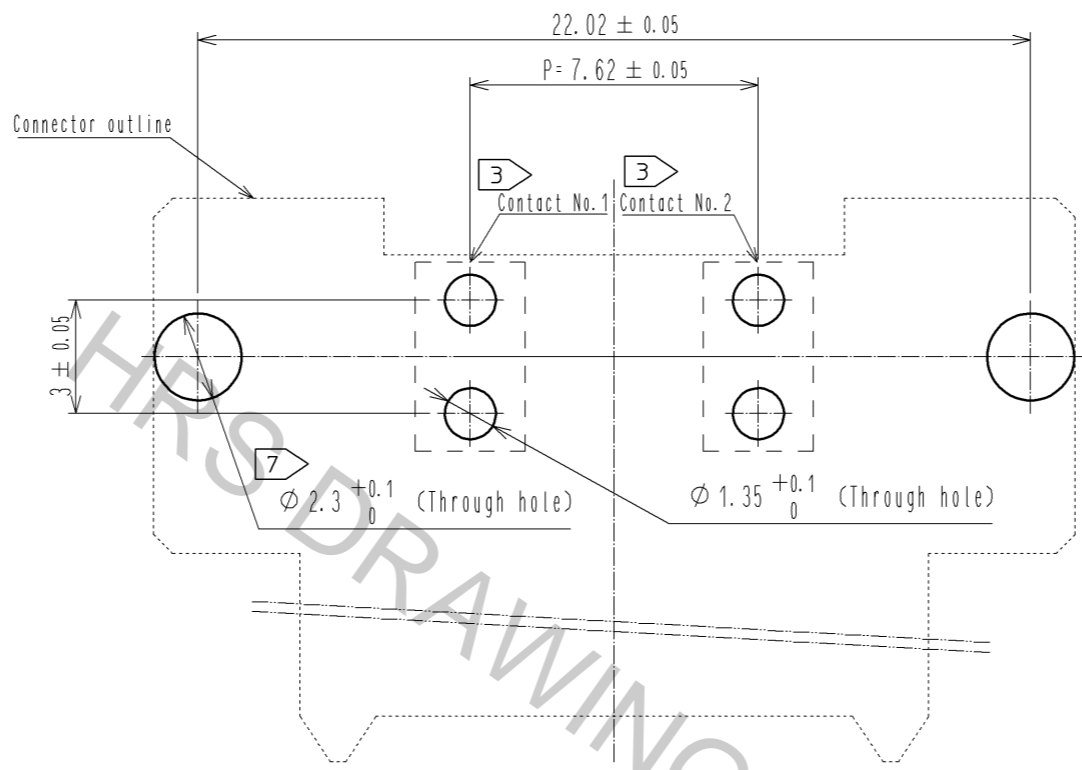

$\triangleleft 1$ Drawing for packaging(1:2)

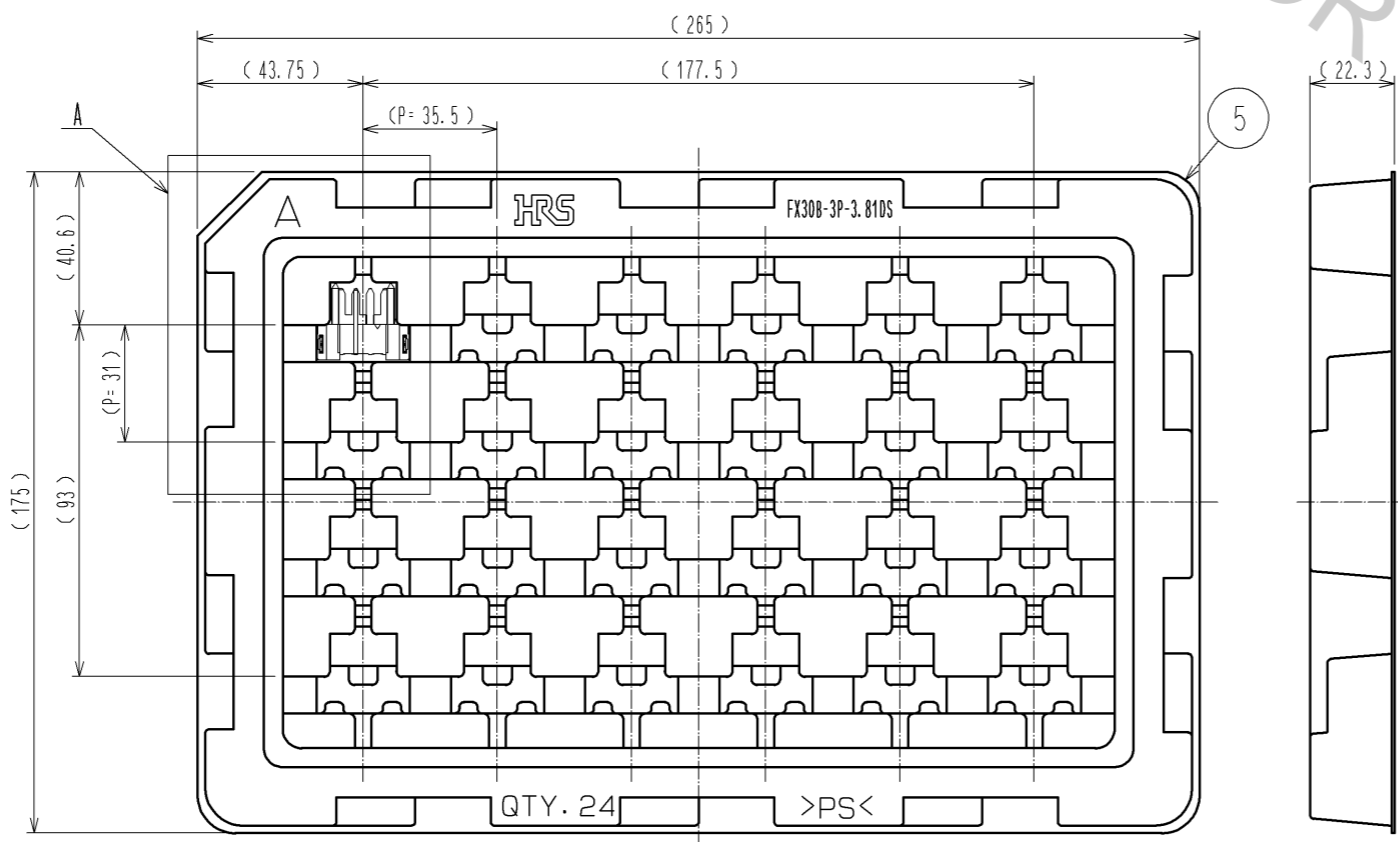

A(1:1)

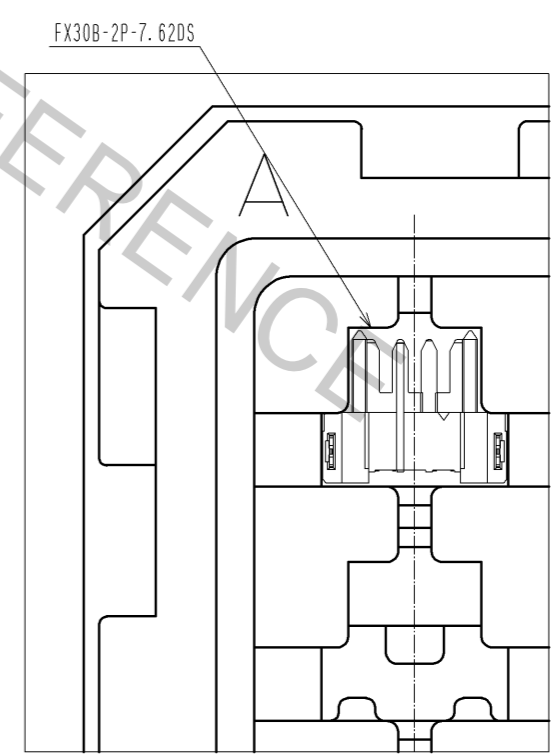

HRS	DRAWING NO.	EDC3-359163-00	$\triangleleft 2/2$
	PART NO.	FX30B-2P-7.62DS	
	CODE NO.	CL570-3404-8-00	